

Dixon Systems

CT-22 Turret

Owner's Manual

Dixon Systems' CT-22 Turret is designed and styled to work with the SP-16 Broadcast console but it's simplicity allows it to be used with almost any console. All functions are simple ground starts. The turret allows control of two microphones and contains two independent high quality headphone amplifiers. Talkback functions are also included.

All audio inputs to the unit are balanced, nominal +4dB level.

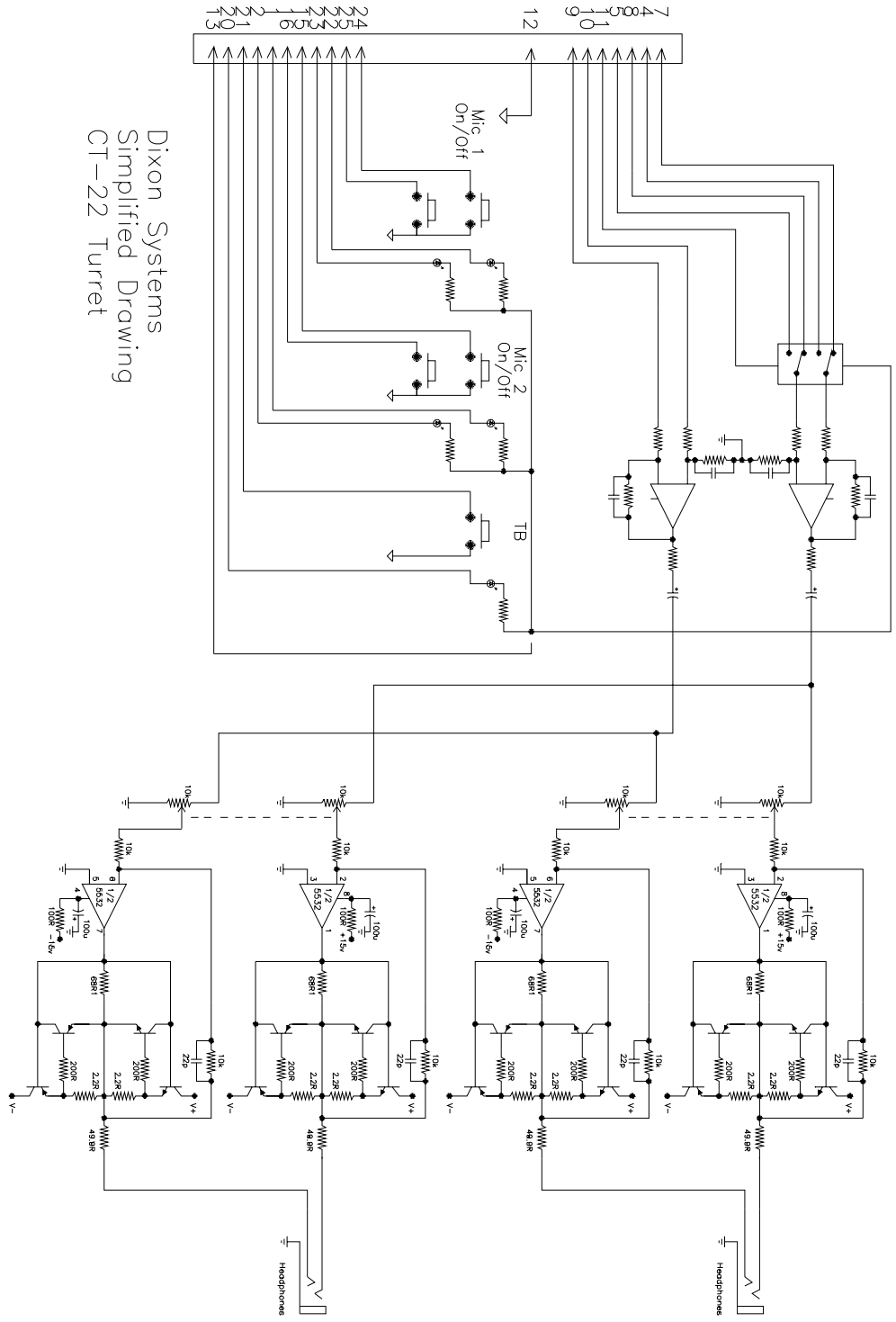

Dixon Systems
Simplified Drawing
CT-22 Turret

Dixon Systems

CT-22

Turret Pinout

(DB25 connector on rear panel)

- 1) Mic 2 Tally "on"
- 2) Mic 2 Tally "off"
- 3) NC
- 4) Talkback audio in (-)
- 5) Talkback audio in (+)
- 6) NC
- 7) Pgm audio in Right (-)
- 8) Pgm audio in Right (+)
- 9) Pgm audio in Left (-)
- 10) Pgm audio in Left (+)
- 11) TB Rcv Gnd Start
- 12) Logic Ground
- 13) +24VDC (in from console)
- 14)
- 15) Mic 2 "on" Switch
- 16) Mic 2 "off" Switch
- 17)
- 18)
- 19)
- 20) TB Tally Gnd Start
- 21) TB Switch
- 22) Mic 1 Tally "on"
- 23) Mic 1 Tally "off"
- 24) Mic 1 "on" Switch
- 25) Mic 1 "off" Switch

Note: All controls are ground start. Pressing a Mic 1 'on' button for example simply connects pin 24 to logic ground. Connecting pin 22 to logic ground will light the tally light on the Mic 1 switch.

+24 volts DC is all that's required from your console.

Notes:

Dixon Systems
580 Danforth Road
Toronto, On. Canada M1K-1E3
www.dixonsystems.com
E-mail: helpdesk@dixonsystems.com